

LESA HI-MOVE PLATE DOWEL SYSTEM

LESA HI-MOVE PLATE DOWEL SYSTEM

The Lesa Hi-Move plate dowel system uses plate dowel technology to replace traditional dowels in shrinkage compensating concrete, stressed slabs and fibre slabs. Hi-Move dowels consist of two parts. The first being a high-quality, high-density, one-piece plastic nail on sleeve. The second being a 10mm parallel side steel plate.

The Hi-Move plate dowel system enables this unique sleeve to be cast into new slabs without having to penetrate formwork, thus eliminating damage to the forms. The built-in ring shank nails make installation quick and easy and also ensure accurate dowel alignment.

This is achieved by the sleeve generating a precise void in the concrete into which the dowel plate can be inserted at the optimum time of construction. The parallel sided steel plate ensures constant bearing at all times while the tapered sleeve allows progressive lateral movement as the concrete shrinks and cures.

The construction of the sleeve is such that it ensures once the dowel plate is inserted into the sleeve an effective seal is formed around the dowel to prevent concrete slurry from entering the sleeve.

Note: For additional lateral movement requirements, two sleeves can be used, back to back. This is an important issue that is often over-looked when on-site fabrication of dowel sleeves using oversized conduit is used.

Hi-Move plate dowels are available in black steel, stainless steel, or hot-dip galvanised. For spacing of Hi-Move plate dowels, please contact Lesa Systems.

SAMPLE DOWEL CAPACITY CHART 32 MPa Concrete - 150mm SLAB

Joint Opening	Lesa Dominator Dowel 75/10	Lesa Hi-Move Dowel 100/10	Diamond Dowel 6mm	Diamond Dowel 10mm	100/6 Plate Dowel	50 x 6 Load Plate	50 x 10 Load Plate	16mm Square Dowel**	20mm Square Dowel**
5mm	<u>31</u>	<u>32</u>	<u>30</u>	<u>30</u>	26	13	21	16	26
10mm	30	31	<u>29</u>	<u>29</u>	26	13	21	16	26
15mm	<u>30</u>	<u>31</u>	23	<u>29</u>	21	10	21	16	26
20mm	<u>30</u>	<u>31</u>	16	<u>28</u>	16	8	21	16	26
25mm	26	<u>30</u>	11	<u>28</u>	13		17	14	26
30mm	22	29	8	23	10		14	12	23
35mm	19	25		17				10	20
40mm	16	22		13					17
* Note: <u>37</u> Underline indicates that punching governs									
**Note: Excludes punching									
Refer to Lesa Systems for specific load requirements									

LESA HI-MOVE PLATE DOWEL

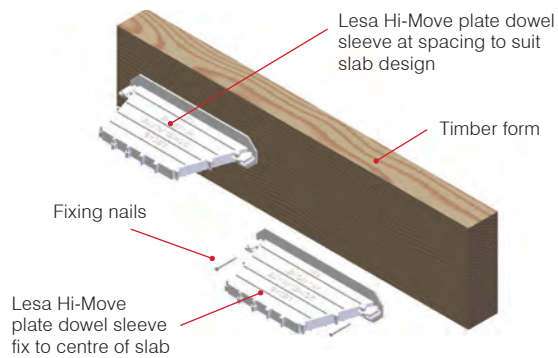

STEP 1: Mark the form for slab centre and Hi-Move plate dowel spacing. Using nails provided fix the Hi-Move dowel sleeve to the form.

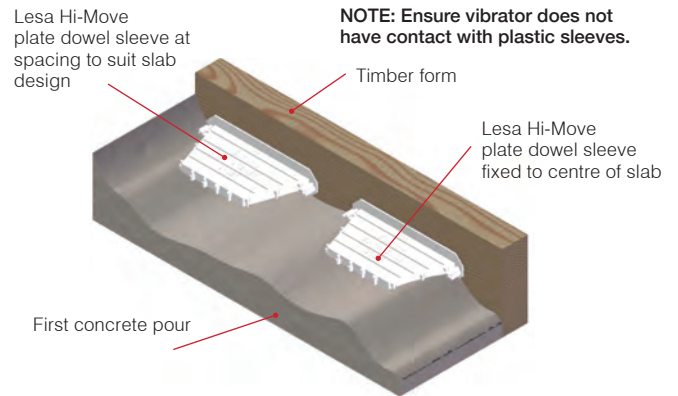

STEP 2: Set the form to line and level as normal. Place and finish concrete. Edge of slab must be vibrated to consolidate concrete around the Hi-Move sleeve.

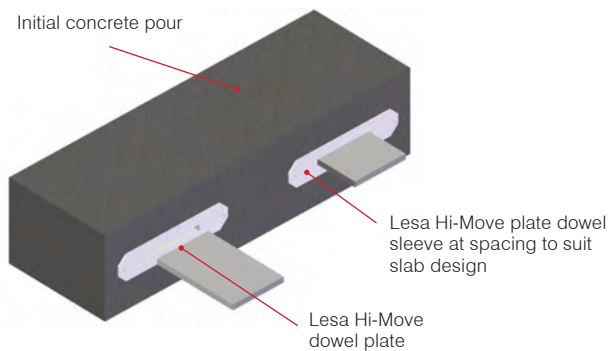

STEP 3: Strip the form. Forms should be cleaned and stored for reuse. Insert the Hi-Move plate dowel when required prior to concrete pour.

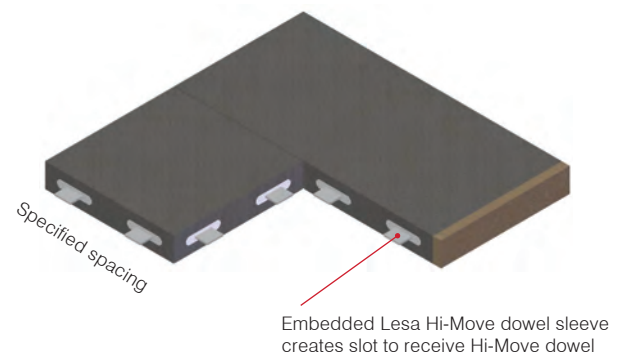

STEP 4: Pours proceed after plate installation.

